

2

1

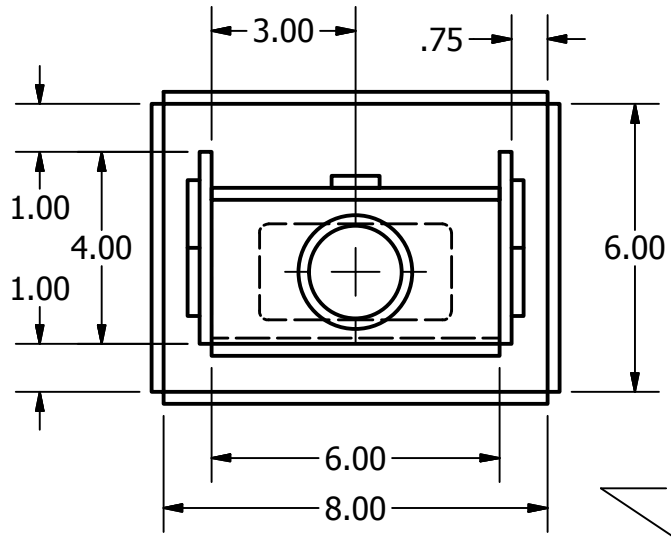

**NOTE:** FRONT HORIZONTAL PLATES ARE 3/8" AND ARE **RECESSED** INSIDE 1/8"

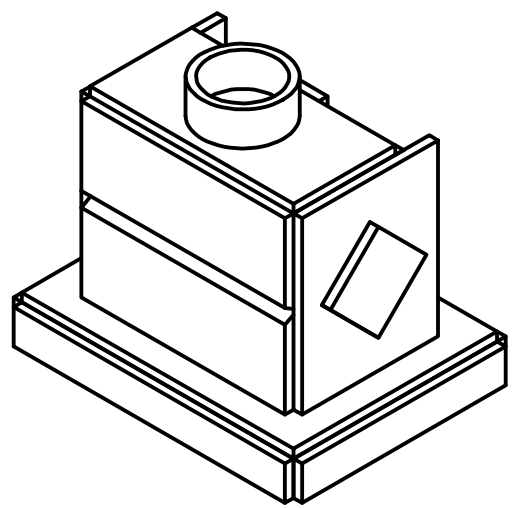
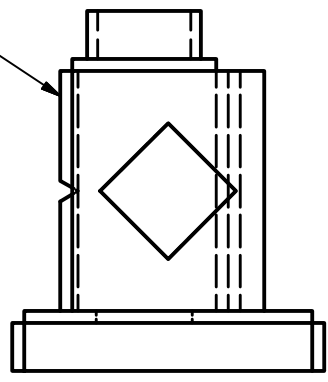
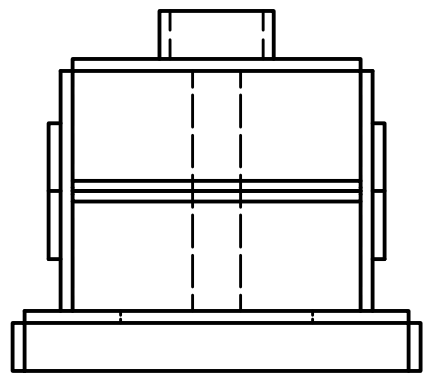

DRAWN Doyle	1/6/2019	TITLE DSBN Welding Skills Challenge		
CHECKED				
QA				
MFG				
APPROVED		SIZE A	DWG NO	REV
		DSBN SKILLS WELDED PROJECT ASSEMBLY		
		SCALE	SHEET 1 OF 3	

2

1

B

B

A

A

PARTS LIST			
ITEM	QTY	PART NUMBER	DESCRIPTION
1	1	1-Base Platform	
2	2	4-Base End	
3	2	3-Base Edge	
4	2	9-Side	
5	2	8-Face Horiz Bevel	
6	1	2-Back	
8	1	5-Back Brace Applique	
9	2	7-End Applique	
10	1	6-Top Bevel	
11	1	10-2 Inch Top Pipe	

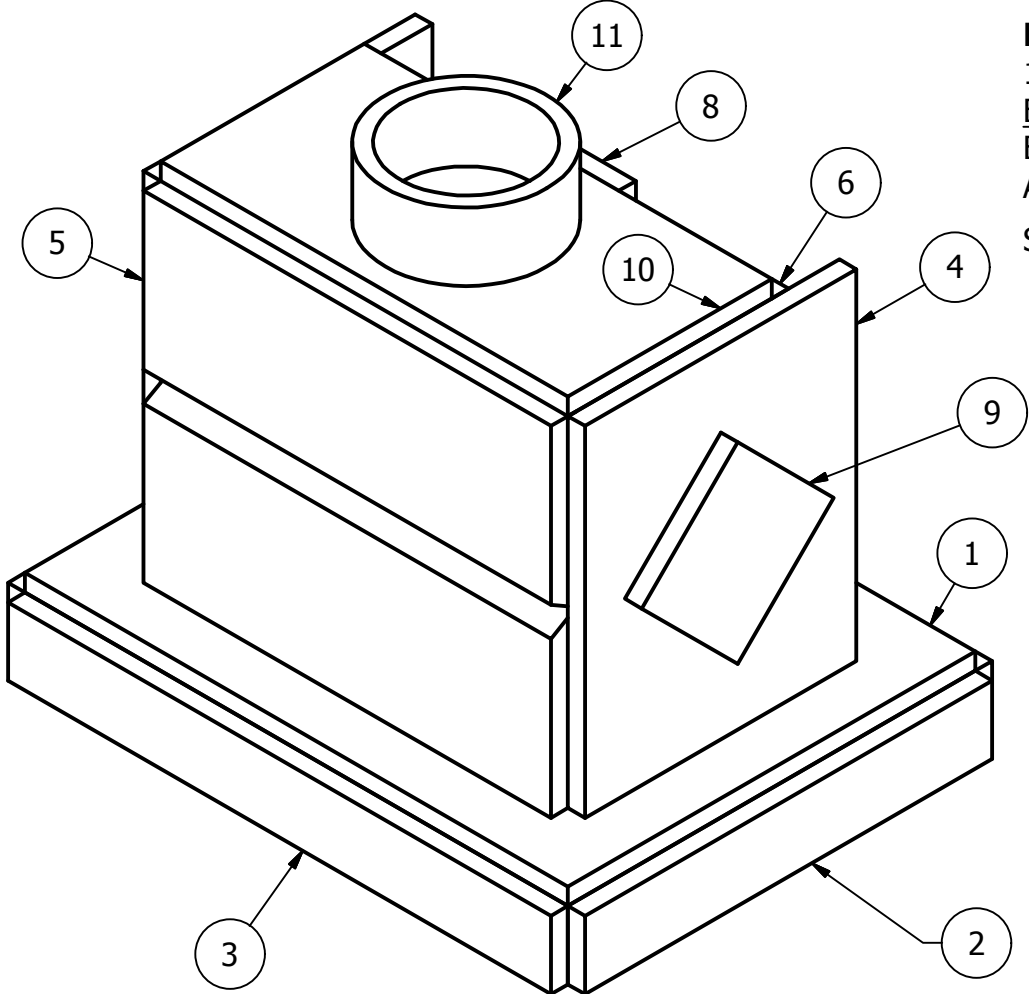

**NOTE:** ALL MATERIAL IS 1/4" THICK EXCEPT THE FRONT BEVELED PLATES WHICH ARE 3/8" WITH A STANDARD 30° BEVEL

DRAWN Doyle	1/6/2019		
CHECKED		TITLE	
QA		DSBN Welding Skills Challenge	
MFG		SIZE A	DWG NO
APPROVED		DSBN SKILLS WELDED PROJECT ASSEMBLY	
		SCALE	REV

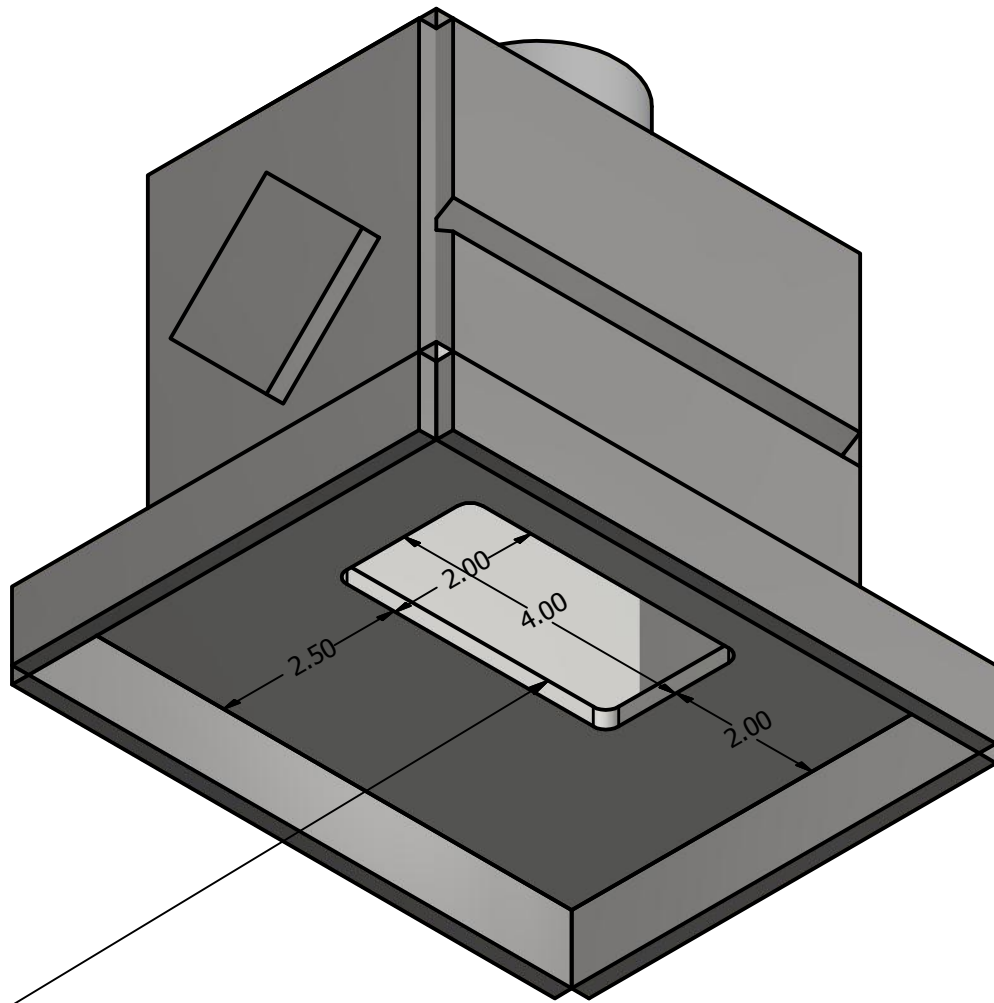

HOLE IN BOTTOM IS TORCH CUT  
**AFTER** ALL WELDING IS DONE

DRAWN Doyle	1/6/2019	TITLE  DSBN Welding Skills Challenge		
CHECKED				
QA				
MFG				
APPROVED				
		SIZE A	DWG NO	REV
		SCALE	DSBN SKILLS WELDED PROJECT ASSEMBL	
				SHEET 3 OF 3